

U2

envirotanks

Workshop Tanks  
for Gear oil, Engine oil  
& Waste oil

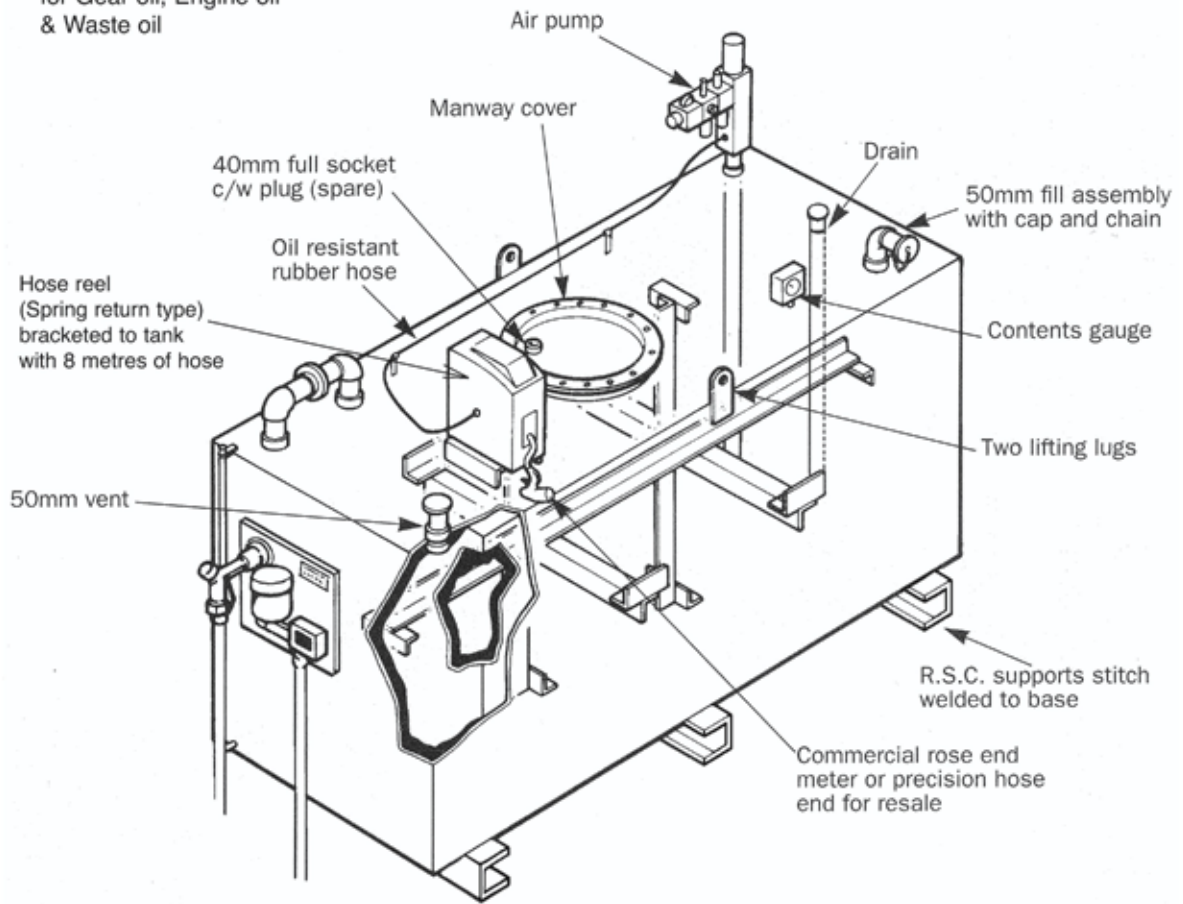

The latest technology in the storage of lubricating, gear and hydraulic oils, etc.

Autolube Envirotank is one of the most environmentally safe ways of storing most workshop fluids. Specifically designed with slimline dimensions to fit into the smallest of workshop areas.

The Autolube Envirotank can also be sited externally with very little maintenance as being a sealed unit no rainwater can enter the bunded area.

Various fittings are available to suit your requirements, so the Autolube Envirotank can be delivered to site ready to use.

Options	Notes	Finish
Electric oil dispersing pump complete with flowmeter, hose and nozzle. Suitable for a 240V, 50Hz, single phase electrical supply, (Pulse output optional if connection to a fuel management system if required) Waste oil Tank with sump and extractor pipe.	Outer skin designed to contain 110% of inner tank volume. Lubricator filled with anti-freeze for external use, recommended air inlet pressure 90lb/in <sup>2</sup> . Pulse transducers and solenoid valves can be fitted for connection to fuel monitoring/management systems.	One coat of zinc phosphate primer, one coat of green oil resistant paint.

Ref.	Capacity Nominal Litres	Length L mm	Width W mm	Height H mm	Weight in kilos	PLT Thickness mm
D10	1136	1727	610	1219	398	3
D11	1363	2058	610	1219	452	3
D12	1818	1700	1000	1219	491	3
D13	2727	2510	1000	1219	651	3
D14	4545	2743	1219	1525	891	3

Autolube Envirotank Rectangular Enclosed Bunded Storage Tank